

## User interface CurrentVIEW

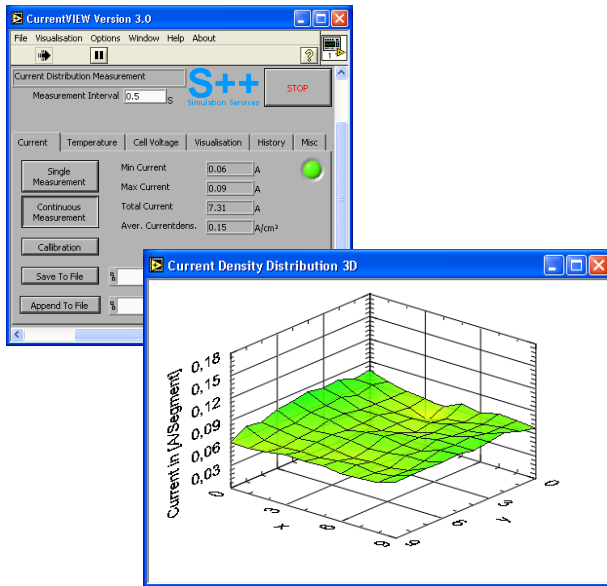

The user interface **CurrentVIEW** is easy to use and self-explanatory. It allows:

- + single and continuous measurements
- + visualization in 2D, 3D and as values
- + saving data as text files in spreadsheet format
- + saving data as pictures in jpg format
- + saving and reviewing of data streams.

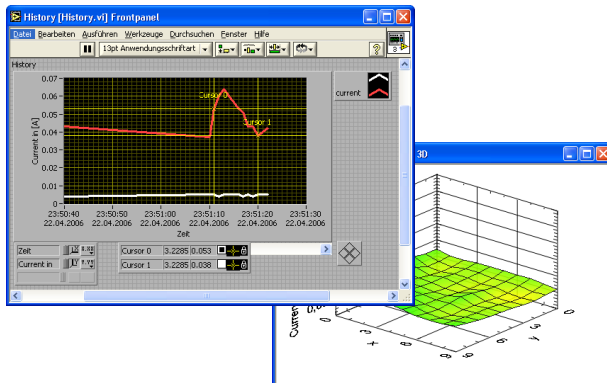

Also a dll can be introduced into an existing environment.

## Specifications

<b>general data</b>	
current measurement range	a wide range is possible
measurement time for current	depends on the amount of measurement cells and evaluation electronic
position of measurement	at an arbitrary position in a stack up to 60V (higher optional) or single cells
<b>sensor plate</b>	
segments	gold plated
size of measurement cells	depends on the design
thickness	0.7mm
maximal operating temperature	100°C
<b>electronic</b>	
analog switches	40 per board, can be cascaded
interface	USB-Interface
power supply	over USB
operating environment	0-40°C, humidity: no condensation
<b>software</b>	User interface and device drivers for Windows 2000 and Windows XP

## Contact:

**S++ Simulation Services**  
 Gräfin-Justitia-Straße 2  
 82544 Egling/Thanning  
 Germany

**Telephone:** +49-(0)8176/998396-0  
**Telefax:** +49-(0)8176/998396-3  
**E-mail:** info@splusplus.com  
**Web:** www.splusplus.com



© 2008 S++ Simulation Services, Vers. 30.03.2009

## current scan shunt

Simple method for current density distribution measurement in fuel cell stacks.

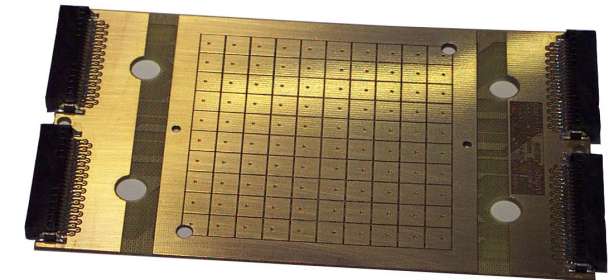

- + detailed analysis of flow fields
- + detailed analysis of materials
- + optimization of fuel cells
- + fault diagnostics in fuel cells
- + long-term tests
- + resolution depends on design
- + current range depends on design
- + standard devices are available
- + special designs on request
- + mass production possible

With the **current scan shunt**, the current density distribution in fuel cells can be measured. Because of the simple internal structure it is suitable for mass production. It is easy to use and the evaluation electronics can be connect via USB to any computer.



In a fuel cell the local conditions differ, which leads to an inhomogeneous mass conversion resulting in an inhomogeneous current production. One of the keys to a better understanding of PEM fuel cells, DMFC and other electrochemical cells is the measurement of the current density distribution. It is important for a save and reliable operation as well as a high lifetime.

## Application

The device of type **current scan shunt** shown on the first page has a resolution of 10 x 10 measurement cells and an active area of 50cm<sup>2</sup>. Because of the simple internal structure it is suitable for mass production. So the **current scan shunt** can also be applied in series production of fuel cells. It can be used for example for control applications. The picture below shows the sensor plate.

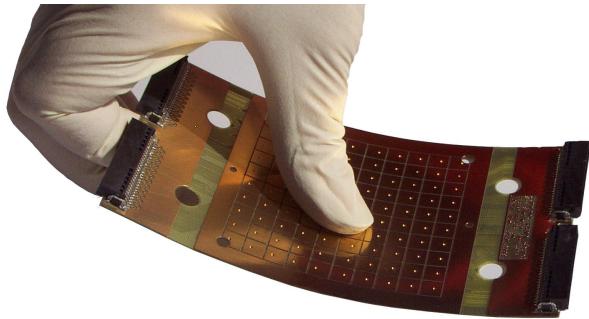

The sensor plate shown above has a thickness of 0.7mm.

Because the sensor plates are very thin they can be laminated together with a thicker part where arbitrary channels can be milled into the surface. So if it is wished by the customer the sensor plate can be used as a flow field and the gas diffusion layer can be placed directly on the gold plated sensor plate. The sensor plate can be placed at an arbitrary position in the stack.

Because of the simple internal structure the sensor plates are suitable for mass production.

The next picture shows a typical current distribution.

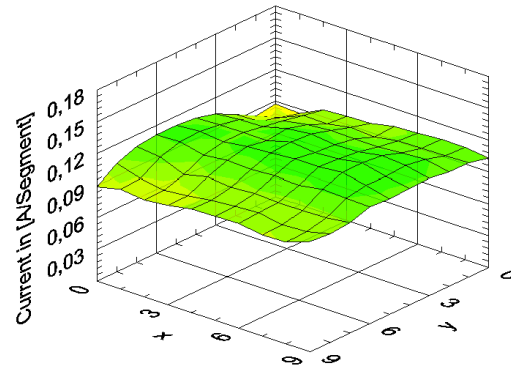

## Measurement Principle

The devices of **current scan shunt** series use a low ohmic shunt resistor for current measurement. We produce two different designs. The first one is made out of material with a very low temperature coefficient. In this case the measurement is temperature independent and no further calibration is necessary. This is an efficient and easy way for measurement. The following picture shows some of the internal resistors during production.

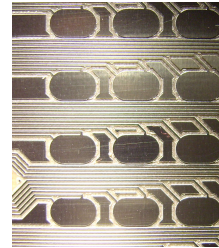

The second design is made from a special copper layer. Because of the high temperature coefficient of copper a temperature compensation is necessary during the measurement.

The **current scan shunt** is produced in licence of the DLR (German Aerospace Center).



For both design the signals from the shunt resistors are connected to a multiplexer which automatically switches the signals to an amplifier and evaluation electronic with Analog-to-Digital converter. This is shown in the following picture.

The resolution is limited, because of the complexity. The complexity grows quadratically with the number of rows and columns of measurement cells. For each measurement cell two wires are necessary, therefore for an array with n x n measurement cells 2n<sup>2</sup> wires are necessary.

So the current scan shunt is the best choice if there is enough space for the wires, especially for small fuel cell or when a low resolution is sufficient. For large fuel cells we recommend the **current scan line** device of our successful current scan product line, which works in a different way and has a linear complexity.

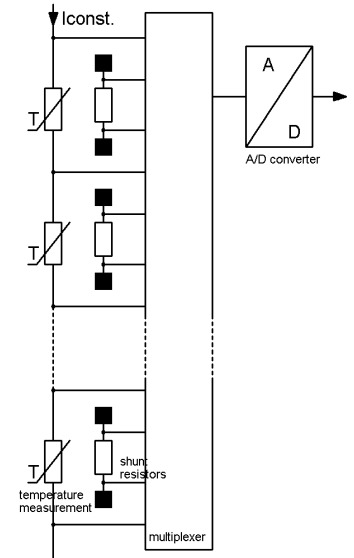

## Available standard device

Standard devices are available with 25cm<sup>2</sup> and 50cm<sup>2</sup>. The following picture shows a sensor plate equipped with flat ribbon cables to the electronic, inserted into a 50cm<sup>2</sup> single cell fuel cell.

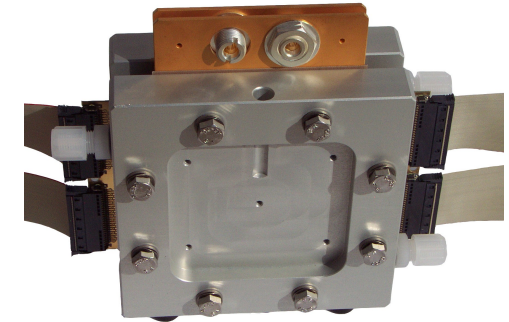

The data acquisition system is equipped with a USB interface.

## Custom made devices

We realize nearly any custom required design. The only restriction for the measurement cells is the available space for the internal wires. The maximal size is nearly not restricted and depends only from the technical producibility.