

User interface CurrentVIEW

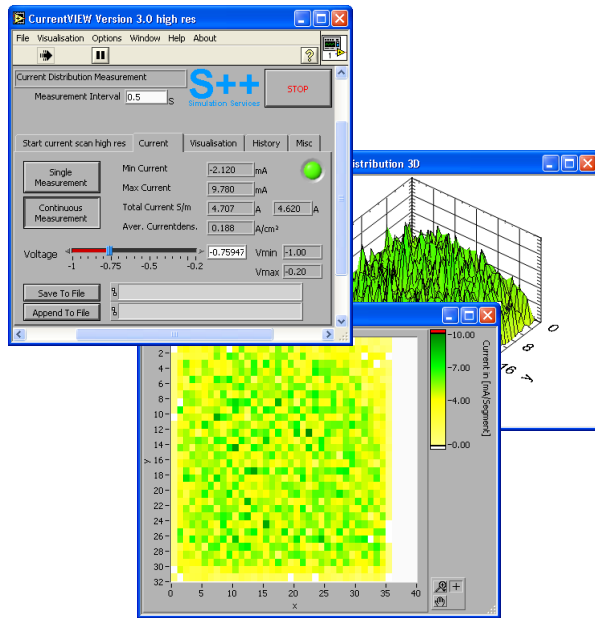

The user interface **CurrentVIEW** is easy to use and self-explanatory. It allows:

- + single and continuous measurements
- + visualization in 2D, 3D and as values
- + saving data as text files in spreadsheet format
- + saving data as pictures in jpg format
- + saving and reviewing of data streams.

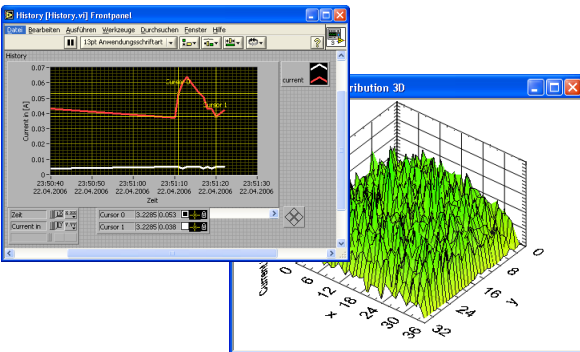

Also a dll can be introduced into an existing environment.

Specifications

general data	
current measurement range	0..20mA(measurement cell)
resolution of current measurement	0.01mA
measurement time for current	1.5 seconds for 1000 measurement cells
position of measurement	at the anode or cathode in a single cell
base plate with segments	
segments	gold plated
size of measurement cells	typical in the range from 0.01cm ² to 0.04cm ²
thickness	2mm
maximal current	20mA per measurement cell
maximal operating temperature	100°C
electronic	
multiple loads	64 per board
interface	USB-Interface
power supply	AC Input 110VAC or 230VAC, 50-60Hz
operating environment	0-40°C, humidity: no condensation
software	
	User interface and device drivers for Windows 2000 and Windows XP

Contact:

S++ Simulation Services
 Gräfin-Justitia-Straße 2
 82544 Egling/Thanning
 Germany

Telephone: +49-(0)8176/998396-0
Telefax: +49-(0)8176/998396-3
E-mail: info@splusplus.com
Web: www.splusplus.com



© 2008 S++ Simulation Services, Vers. 29.03.2008

current scan high res

Current density distribution measurement in fuel cells with high resolution.

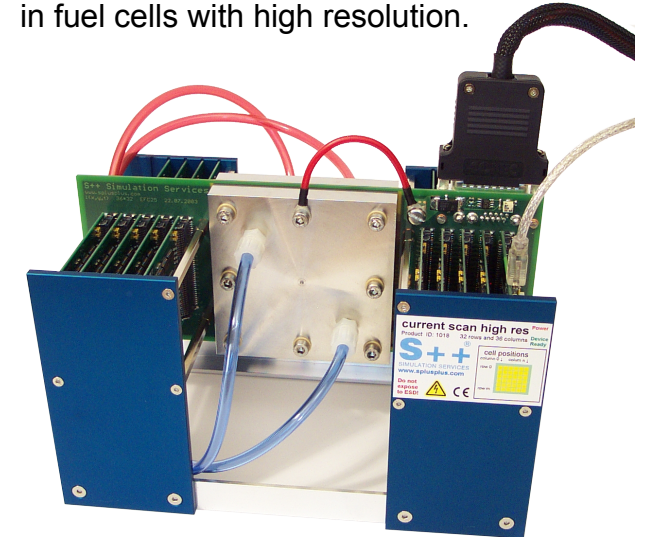

- + detailed analysis of flow fields
- + detailed analysis of materials
- + optimization of fuel cells
- + fault diagnostics in fuel cells
- + resolution of about 1 x 1 mm
- + current range up to 2A/cm²
- + standard devices are available
- + special designs on request

With the **current scan high res**, the current density distribution can be measured with a very high resolution. It is connected via USB to any computer and easy to use.



In a fuel cell the local conditions differ, which leads to an inhomogeneous mass conversion resulting in an inhomogeneous current production. One of the keys to a deeper understanding of PEM fuel cells, DMFC and other electrochemical cells is the measurement of the current density distribution. This is important for a save and reliable operation as well as a high lifetime.

Application

The device of type „**current scan high res**“ shown on the first page has a resolution of 32 x 36 measurement cells and an active area of 25cm². The picture below shows a sectional view of the setup.

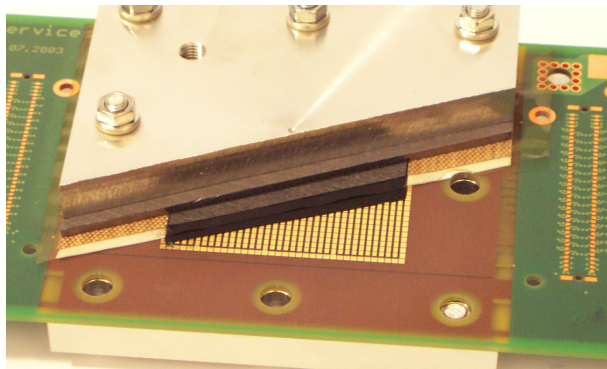

If necessary the gas diffusion layer can be placed directly on the segments. Therefore the channels of the flow field can be milled between the segments. The device is usable as anode or cathode of a single cell.

The picture below shows a typical current distribution.

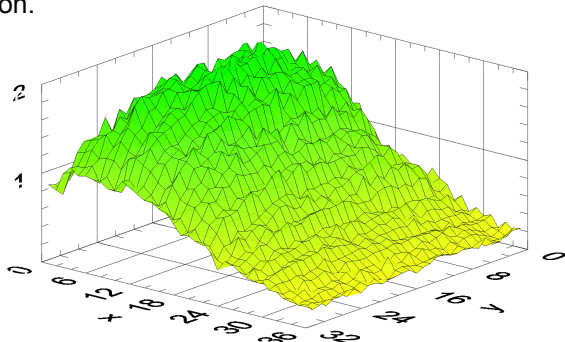

Measurement Principle

The devices of this series use a segmented electrode with segments of about 1mm² connected to single electronic loads through a multilayered printed circuit board.

An electronic load, connected to a segment, is shown in the following picture.

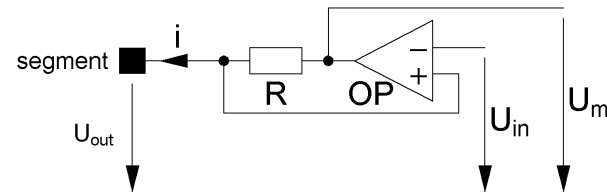

The electronic loads are realized with operational amplifiers which work as current source or sink. So the device can be used on the anode or optionally on the cathode side. The voltage after the resistor R is feed back to the operational amplifier OP. So the voltage U_{out} at the segment is held constant at the voltage of the input U_{in} . The voltage U_m is measured and the current which flows out of the segment or into the segment is calculated with help of the formula

$$i = \frac{U_m - U_{in}}{R}$$

Many of these electronic loads are connected with a multiplexer which switches the voltages U_m to an Analog-to-Digital converter. The inputs are connected together and the voltage U_{in} is provided by an Digital-to-Analog converter. This is shown in the following picture.

The size of the device is limited, because the complexity grows quadratically with the size or resolution. For large fuel cells there is another principle available, which is realized in the devices of the series „**current scan lin**“.

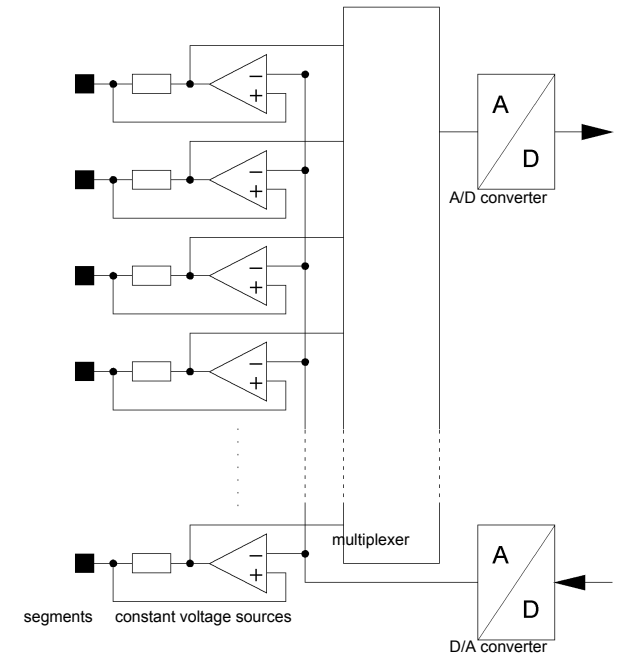

Available standard device

The available standard device has the same size as the 25cm² ECF 25 single cell fuel cell from Electro Chem. It has 32 x 36 segments of 1.47 x 1.64mm on a base plate. 18 boards with 64 electronic loads and a data-acquisition system with USB interface are plugged into the base plate. The power supply is in a 19" housing.

Custom made devices

Nearly any custom made design is possible. The minimal size of the measurement cells is 1 x 1mm. The maximal size is restricted by the current the operational amplifiers are able to deliver. But because of the quadratic complexity the devices of the series „**current scan high res**“ are restricted to small devices. For large fuel cells or fuel cell stacks please ask for a device of the series „**current scan lin**“.